

Original

# INSTRUCTION MANUAL

# DFB SERIES 1

Industrial Sewing Machines

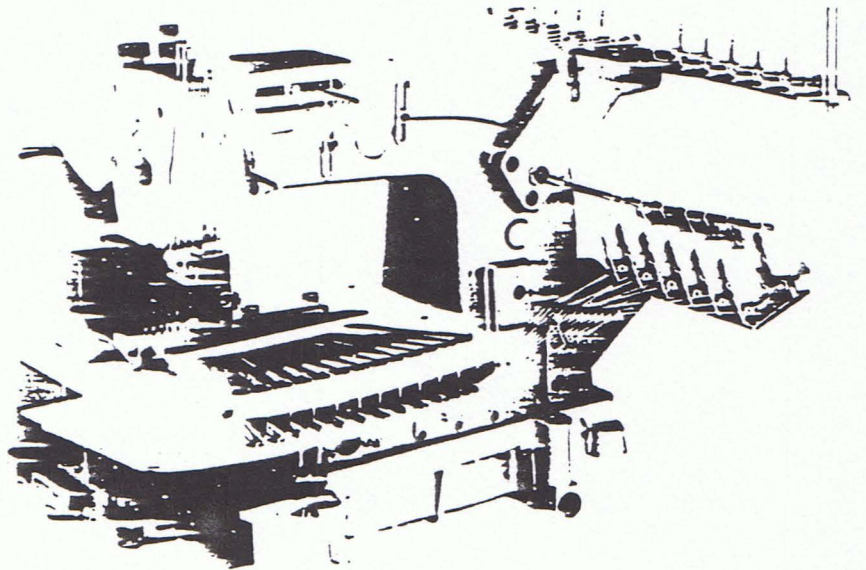

Industrial Sewing Machines  
**Kansai Special**

Instruction manual

model: DFB-1400 series

: DFB-1000 series

INDEX

	page no.
1) Features	1
2) Selection of motor pulley	1
3) Supplying/draining oil	1
4) Setting of needle	2
5) Threading	2
6) Adjustment of needle bar height	3
7) Distance of needle and looper	3
8) Synchronization of needle and looper	3
9) Clearance of needle and looper	4
10) Adjustment of needle guard	4
11) Adjustment of looper thread spreader	4
12) Adjustment of looper thread retaining bar	5
13) Height of feed dog	5
14) Adjustment of rear puller	6
15) Adjustment for Single chain stitch	7
16) Adjustment for Smocking apparatus	8



1) Features

model	1404	1412	1433	1012	1033	PSM
seam type	401	double chain		101	single	smocking
needles	2-4	6-12	25,33	12	25,33	
needle bar stroke	34.5 m/m					
feeding	non-differential					
lubrication	fully automatic lubrication					
max. RPM	4500	4000	2000	2500	2000	2000

Table 1

2) Selection of motor pulley

Caution: operational rotation of hand wheel should be toward the operator(counter clockwise)

R.P.M.	diameter of motor pulley(m/m)	
	50Hz	60Hz
4500	95	80
4000	85	70
2500	55	40
2000	45	30

Table 2

3) Supplying/draining oil (Fig.1)

Recommended oil is "TELESSO 33"

- a) Remove oil viewer A and supply oil until oil is being filled up to the line B of oil gauge C. The oil level should be checked and kept between line B and D while machine is in use.
- b) Draining oil can be done with removing screw E. It is recommended that oil change once in first one month once in every 6 months afterward for stability of machine.

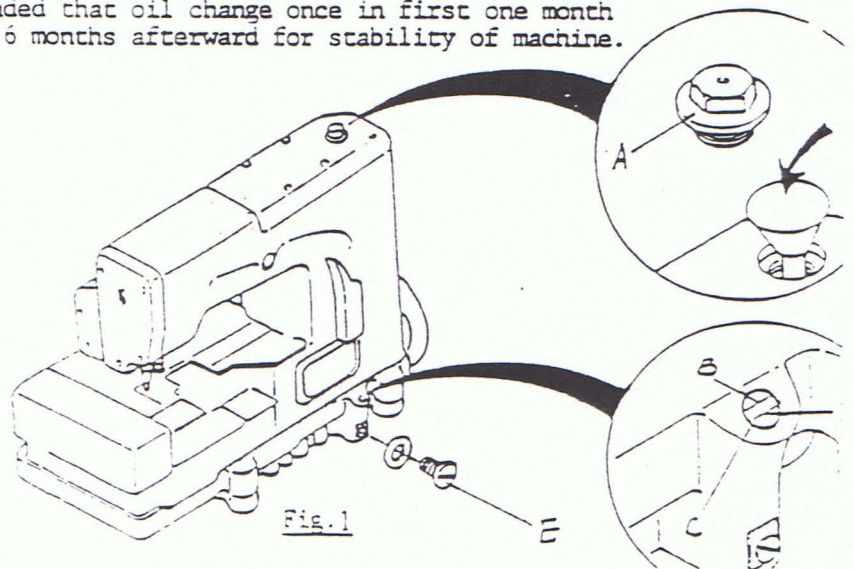

Fig.1

- 4) Setting of needle(Fig.3)  
 Loosen screw A and place needle eye  
 securely across the feeding direction  
 with locating scarf of needle toward  
 left as shown Fig.3.

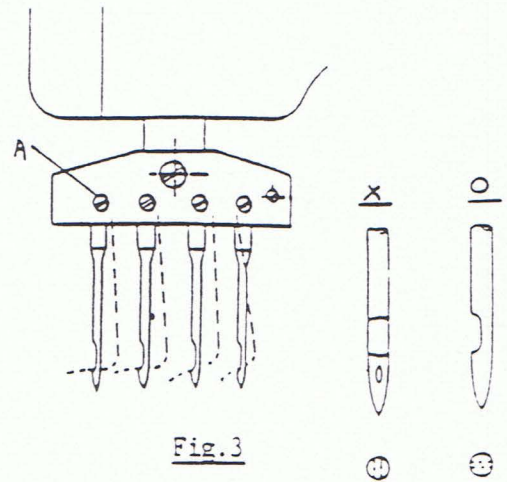
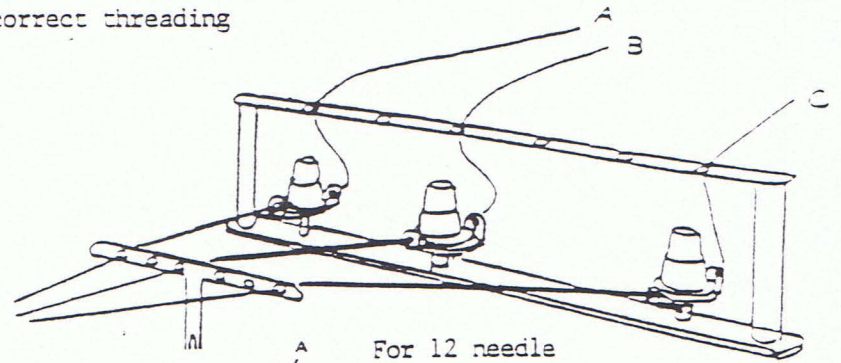

Fig.3

- 5) Threading (Fig. 4)  
 Refer Fig.4 for correct threading



For 12 needle

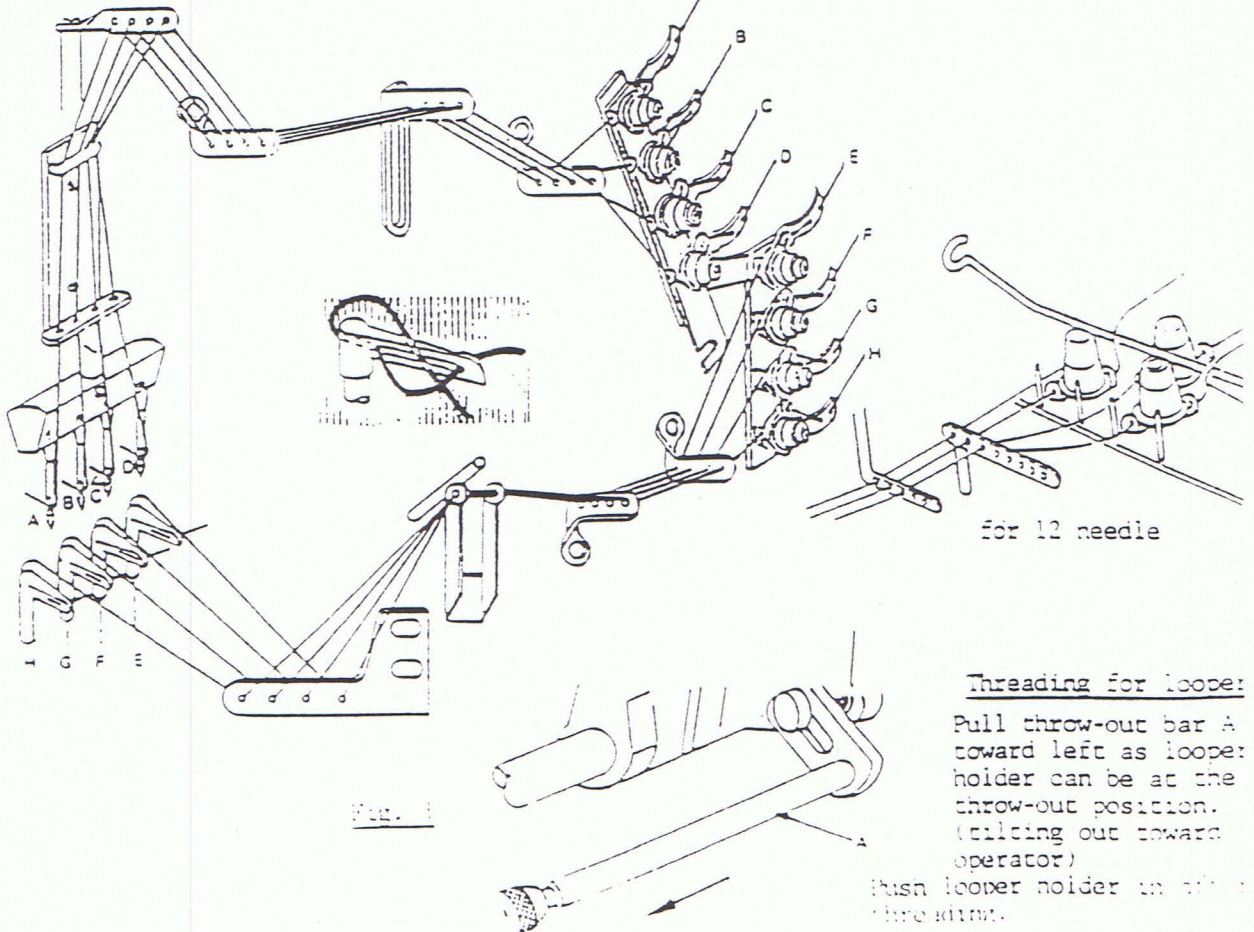

Fig. 4

for 12 needle

Threading for looper:

Pull throw-out bar A  
 toward left as looper  
 holder can be at the  
 throw-out position.  
 (tilting out toward  
 operator)

Push looper holder in after  
 threading.



- 6) Needle bar height (Fig.4)  
 When the needle bar is at the highest of its stroke, the point of needle to the surface of needle plate should be 13.5 m/m. Loosely tighten screw B for this adjustment.

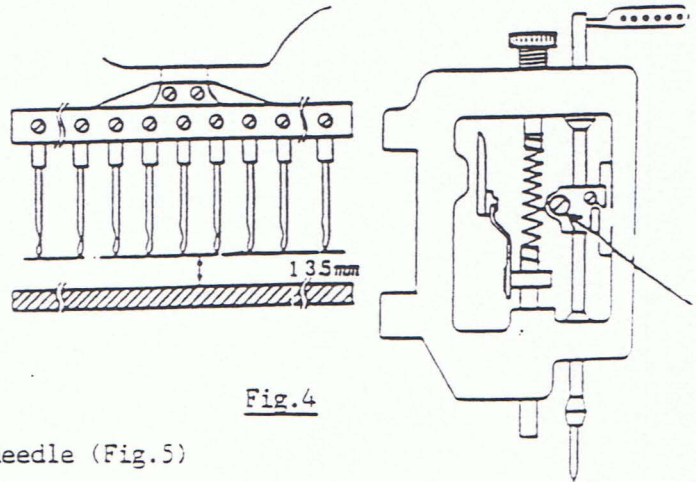
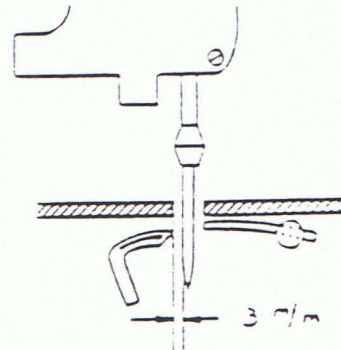

Fig.4

- 7) Distance of looper to the needle (Fig.5)

When the needle bar is at the highest of its stroke, the point of looper to the needle should be 3 m/m.

Loosen screw A Fig. 5 for this adjustment as looper holder can be moved front and backward. Tighten screw A firmly.



- 8) Synchronization of needle and looper (Fig.6)

When the needle bar is on its way upward, the point of looper should locate in the middle of needle scarf (1m/m higher than needle eye).

Also, the needle bar is on its way down, the point of looper should locate 2.5 m/m higher than needle eye (needle eye and looper should be in line.)

To adjust this, loosen screw B Fig.5 and relocate position of eccentric against main shaft. Tighten screw A securely.

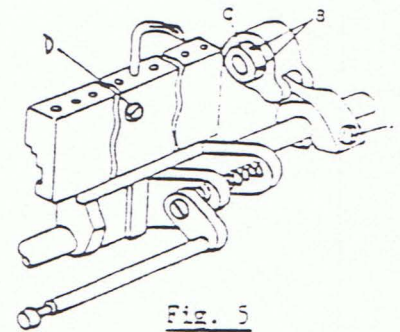

Fig. 5

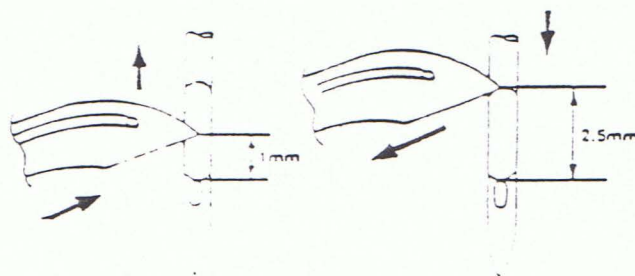

Fig. 6

9) Clearance of needle and looper (Fig.7)

When the point of looper passes by scarf of needle, keep clearance between them should be 0-0.1m/m.

To adjust this, loosen screw D Fig.5

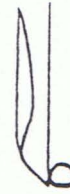

Fig.7

10) Setting of needle guard (Fig.8)

The clearance of needle and needle guard should be 0-0.1 m/m when needle guard is located at the closest position to the needle.

Loosen screw A for this adjustment.

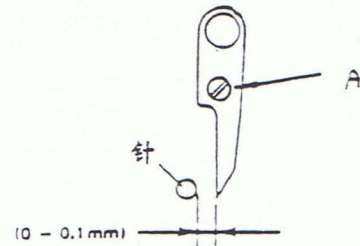

Fig.8

11) Setting of spreader looper (Fig.9)

- a) Flat surface of spreader looper should be parallel with surface of needle plate as shown Fig.9

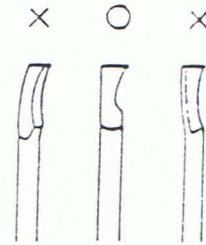

Fig.9

b) Distance of needle to the point of spreader looper (Fig. 10)

Turn hand wheel and locate spreader looper in front of needle then secure the distance of 0.5 m/m between them by loosening screw A.

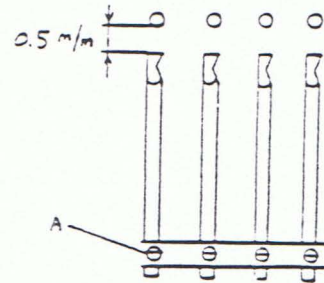

Fig.10

c) Location of spreader looper to looper (Fig. 11)

When spreader bar is at its extreme left end, right side point of spreader looper should be located 0.5 m/m left of right side surface of looper.

To adjust this, loosen screw A so that spreader bar B can be shifted.

At the same time, keep clearance 0.1 m/m between top of looper and lower end of spreader looper.

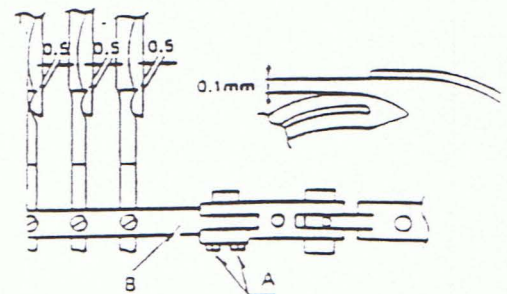

Fig.11



12) Adjustment of thread retaining bar

a) synchronization of retaining bar and looper Fig. 12)

In motion of needle bar downward and point of needle is at the same height of blade of looper, thread retaining bar should start its motion upward.

Loosen screw D on eccentric and shift its location.

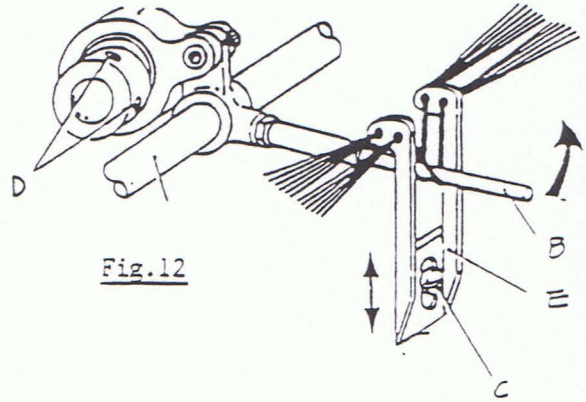

Fig.12

b) retaining volume (Fig. 13)

When retaining bar is at its lowest position, keep the distance 10 m/m from eye to the point where thread is being retained.

Refer table 3 for different type of thread.

thread	distance A m/m
cotton	8
synthetic	8
spun	10
wooly	10

Table 3

This adjustment can be made with loosening screw C Fig.12 as height of eyelet can be changed.

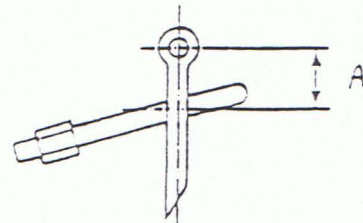

Fig.13

13) Height of feed dog (Fig. 14)

When the needle bar is at the highest of its stroke, the height of peak of teeth to needle plate surface should be 1 m/m-1.2 m/m.

Loosen screw C for change of height of feed dog and secure the height with screw D.

Teeth should be made parallel with surface of needle plate by adjusting screw X while screw Y is loosened.

Tighten screw C and Y after adjustment is done.

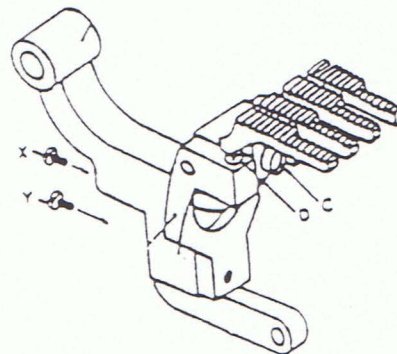
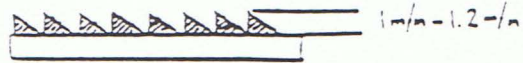

Fig. 14

#### 14) Adjustment of rear puller

##### a) Synchronization to needle bar (Fig. 15)

In upward motion of needle bar and the point of needle is located within the thickness of presser foot (1.5 mm higher than surface of needle plate.), puller should start to be effective. Loosen screw A and secure the location of eccentric. Tighten screw A after adjustment is done.

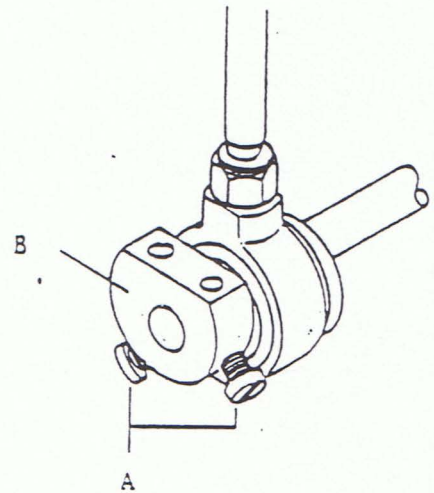

Fig. 15

##### b) The amount of travel of the puller (Fig. 16)

Feed length and the amount of travel of the puller normally be maintained the same. To adjust this, loosen nut C, move ball joint assembly inwardly (toward upper shaft) in connecting lever A to acquire more feed action, outwardly acts the reverse. Retighten nut C.

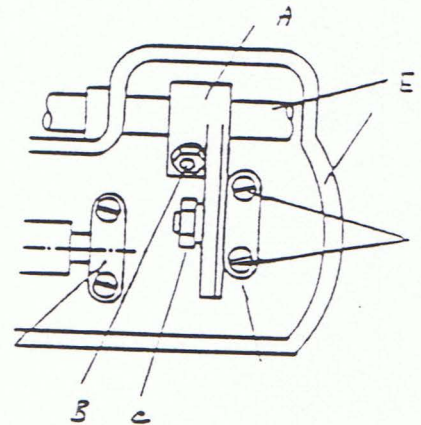

Fig. 16

##### c) Fine adjustment of travel of the puller (Fig. 17)

To adjust this, loosen screw C move puller driving lever B toward operator to acquire more feeding action, outwardly acts reverse. Retighten screw C.

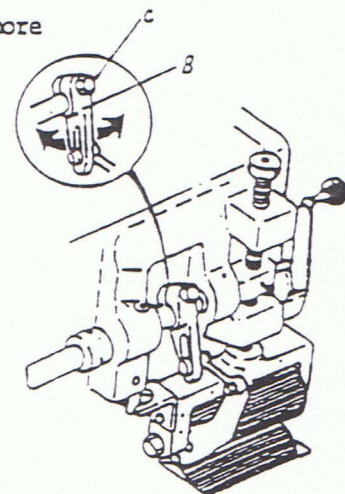

Fig. 17



15) Adjustment of single chain stitch(type 101)

Applicable model: DFB-1012P, 1025P, 1033P, 1012PSM, 1033PSM

- a) height of needle bar to be refered no.6 page 3
- b) Height of feed dog to be refered no.13 page 5
- c) Distance of looper to the needle (Fig. 18)

When the needle bar is located at the lowest of its stroke, distance from the needle to the point of looper is 1.8 m/m. To adjust this, loosen screw A Slightly but rigid enough to retain its position, and adjust the distance. Retighten screw A.

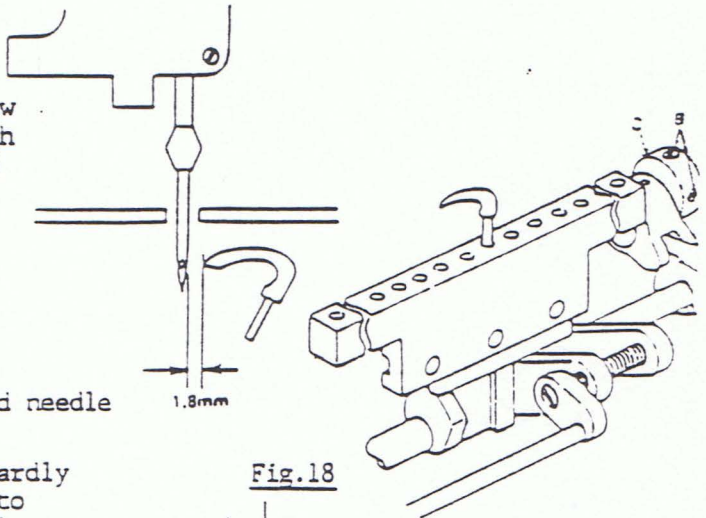

- d) Synchronization of looper and needle (Fig. 19, 20)

In motion of needle bar upwardly and the point of looper is to meet the center of the needle, the height of the point of looper should be 1.5 m/m above the upper part of needle eye.

In motion of needle bar downwardly, the point of needle is to be aligned the most inner part of looper blade with its height.

To assure that the looper point passes to the side of the needle as close as possible without contacting.

To adjust this synchronization, loosen set screw B Fig. 18 and attain the required position. Retighten screw B.

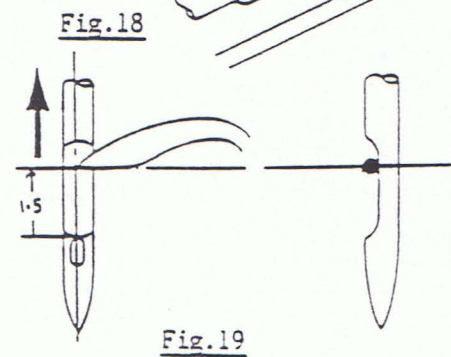

- e) Adjustment of shirring foot (Fig. 21)
- The needle drop is to be made at the bottom of shirring.

To adjust this, loosen screw A move liner B front / rear to attain the required location of needle drop. Retighten screw A.

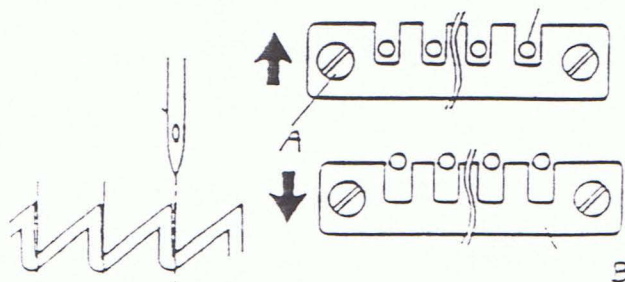
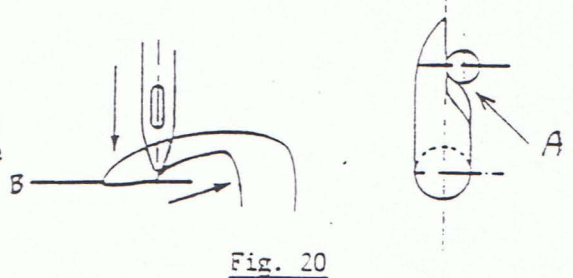

16) Adjustment of Smocking apparatus

Applicable model: DFB-1412PSM, 1433PSM, 1012PSM, 1033PSM

a) Synchronizing needle bar and spreader (Fig. 22)

In downward motion of needle bar, the point of needle corresponds the height of spreader surface, the motion of spreader should be stopped. To adjust this, loosen nut C (Fig.23) clockwise and loosen screw A (fig.23) hold the position of cam D turn hand wheel so that synchronization of spreader is attained.

Retighten screw A and nut C securely. The location of eye of spreader should be aligned in front of needle as shown Fig.22. Loosen screw A Fig.22 so that required position of spreader can be attained.

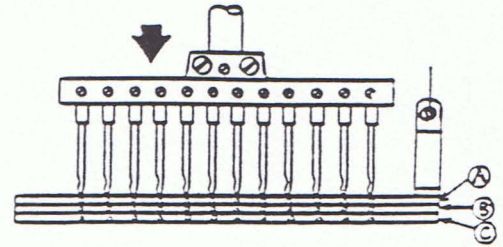

Fig.22

b) Changed of amount of travel of spreader (Fig.24)

Loosen nut B move joint E upwardly in driving lever A to acquire more amount of spreader travel, downwardly acts reverse. Retighten nut B

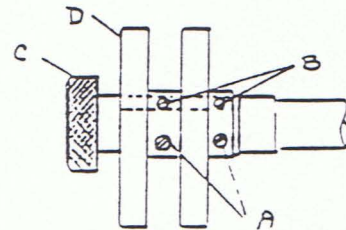

Fig.23

c) Clearance of needle and spreader (Fig.25)

The inner edge of spreader and needle should be kept clearance of 1-1.2 m/m. To attain this, loosen screw A move housing so that distance between surface of needle plate and bottom of housing can be adjusted 15 m/m. Loosen screw B, C, D move spreader upwardly to acquire less clearance, downwardly acts reverse. Retighten screw A,B,C,D securely.

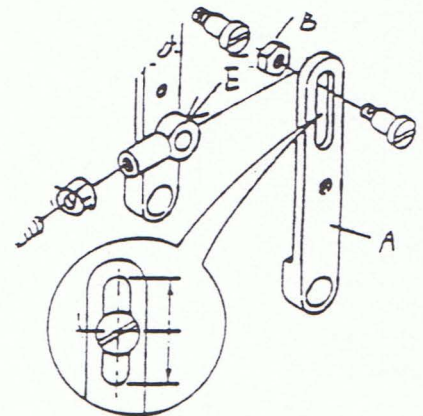

Fig.24

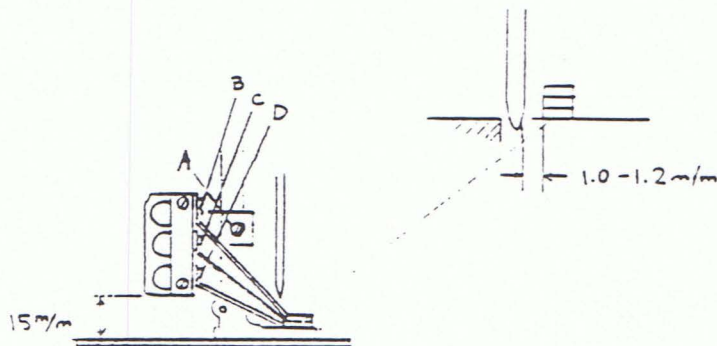

Fig.25